

D.Y.I. Immobilizer – Theft Deterrent Wiring

The following diagram depicts how we wire the D.Y.I. Theft Deterrent System. This diagram is for information purposes only. Automotive Rewire is not responsible for damage that may occur by the installer / owner installing this system in a vehicle. Although this system is proven to work in many vehicles, no warranties are offered or implied.

IMMOBLIZER - "ARMED" STATE

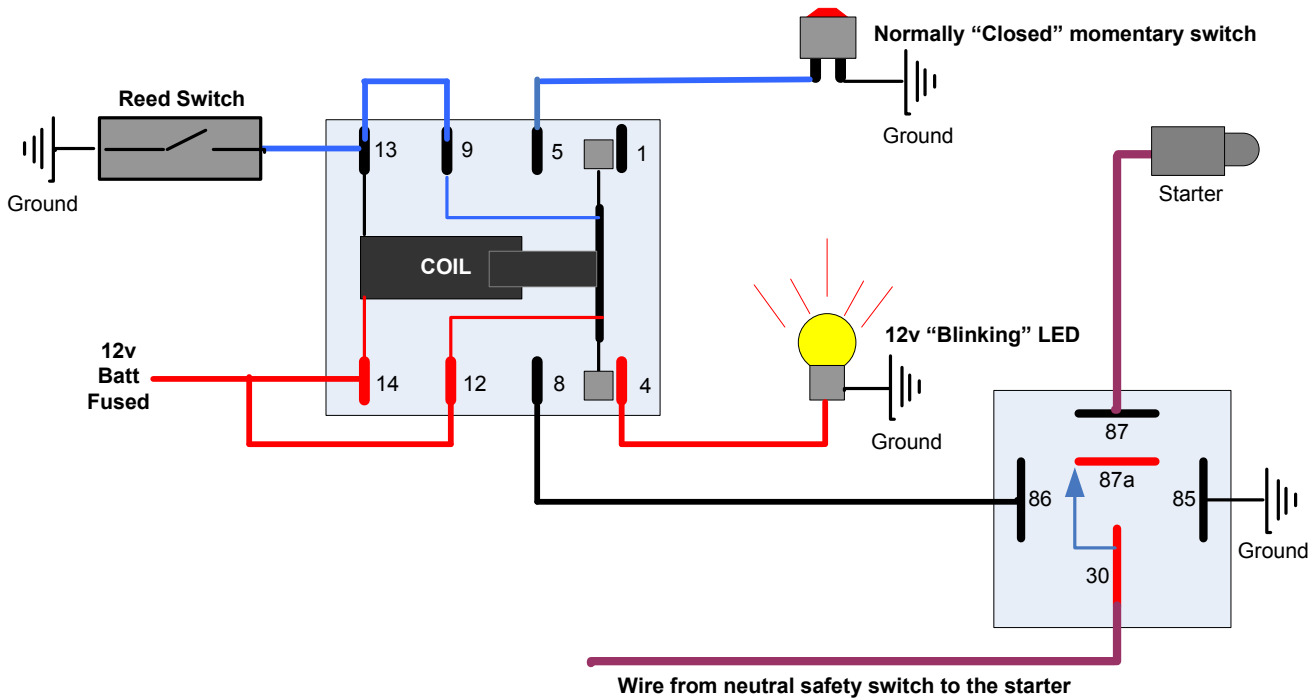

WHAT IS GOING ON HERE ?

There are only 2 things going on during the "Armed" state.

1. The Neutral Safety Switch circuit is broken
2. The 12 volt blinking LED light is blinking

HOW DO I DISARM THE SYSTEM SO I CAN START THE VEHICLE ?

To disarm the system, touch the hidden reed switch with your magnetic device (magnet in an old key fob works great). This will send a ground to the negative side of the DPDT relay coil and pull the contacts off of 1 & 4 and on to 5 & 8. A ground will be picked up on post 5 and passed to post 9 causing the DPDT coil to pull in permanently until the ground is broken by pushing in the momentary switch.

1. The LED light will go off (contact pulled off of 4 and on to 8)
2. 12v is passed to the SPDT relay in turn switching the relay and connecting the neutral safety switch wire.
3. The ground will be passed through the Normally Closed Momentary Switch to post 5. The internal wiring of the DPDT relay will pass the ground from post 5 to post 9. Since you jumped posts 9 & 13, the ground will keep the coil pulled in until you break the ground by pressing the momentary switch.

WHY DO YOU BREAK THE NEUTRAL SAFETY AND NOT ANOTHER CIRCUIT ?

We like to break the neutral safety circuit because in the event of a failure to any of the components, we do not want the vehicle to shut down and leave us stranded on the side of the road. During a failure of any components we will continue to run. If we shut the vehicle down we will not be able to start the vehicle. If the failure is in the DPDT relay, we should be alerted when the LED starts to blink while the vehicle is running. This will tell us not to shut down the vehicle until we are in a spot to work on it.

If the SPDT relay fails, there isn't an indicator to warn us, but that could always be added using post 87a and another LED somewhere. If it is the SPDT relay, we know where it is hidden and we will be running again once we replace the relay or jump the neutral safety wire.

D.Y.I. Immobilizer – Theft Deterrent Wiring

The following diagram depicts how we wire the D.Y.I. Theft Deterrent System. This diagram is for information purposes only. Automotive Rewire is not responsible for damage that may occur by the installer / owner installing this system in a vehicle. Although this system is proven to work in many vehicles, no warranties are offered or implied.

IMMOBLIZER - "UN-ARMED" STATE

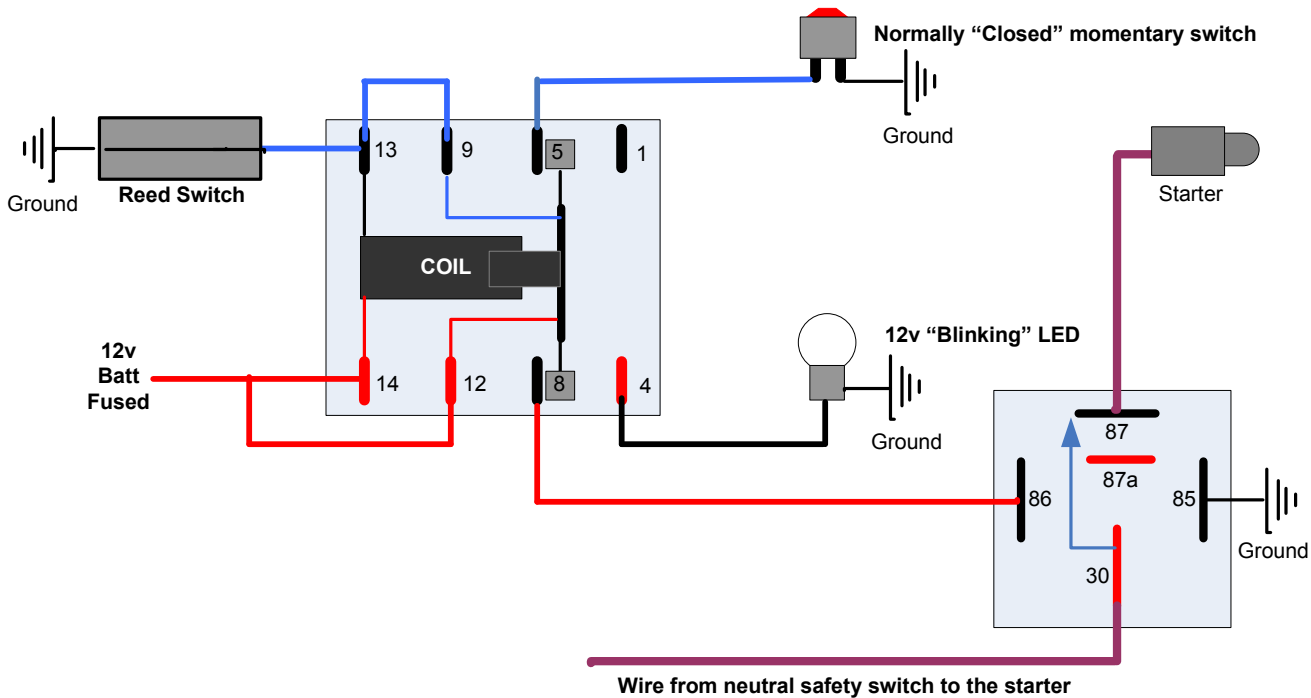

WHAT IS GOING ON HERE ?

When you pass the magnet over the reed switch, the system will be un-armed and allow you to start the vehicle. Once you see the LED light go off, you can then move the magnet away from the reed switch. You don't want to give away the location of your hidden reed switch. Note: The reed switch will re-open when you remove the magnet. It is only shown in the closed position for illustration purpose.

1. The Neutral Safety Switch circuit is completed, or closed.
2. The 12 volt blinking LED light stops blinking

HOW DO I RE-ARM THE SYSTEM ?

To re-arm the system, simply press the momentary switch.