

39 Chevy Sedan Delivery Cowl Vent Wiring

The window switches and cowl vent switch were mounted in the overhead console along with the radio and interior light. We chose to use the Watson's StreetWorks Oval Billet 3 switch panel #L39303X-CSTM



We will use the center switch to control the Rocky Hinge Power Cowl Vent #OCV 01 and the other switches will control the driver and passenger windows. Other than the obvious great look of these switches is that they are only rated for 5 amps which forces us to wire relays to provide the up and down power for the motors. This also means that the gauge of the wire that we have to send up the A-Pillar will be smaller as it will only need to carry a switched ground to latch a relay. Here is how the window switch wiring works:

You will need to have 2 relays for each window function (up and down) and the switches must be momentary on-off-on.

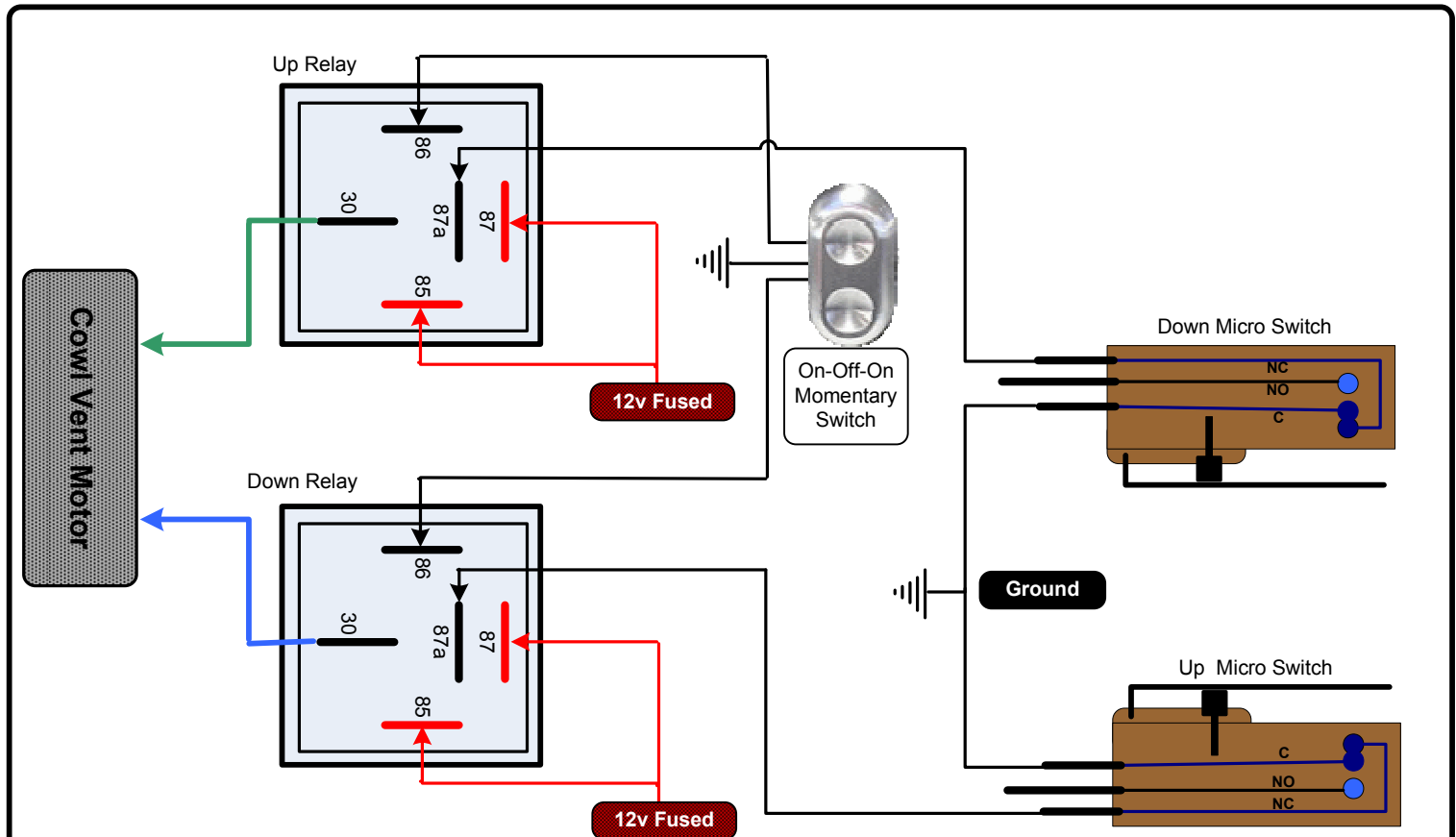

The micro switches are used to limit the motion of the motor in both directions. A ground is passed from the "C" (Common) leg to the "NC" (Normally Closed) legs depending on where the motor is in its rotation. There is a lobe installed on the motor shaft that will make contact with the lever on the micro switch that will interrupt the ground connection to the relay at post 87a. Once the lobe makes contact and interrupts the ground, the motor will not spin any further in that direction. It will, however allow movement in the opposite direction.

The micro switch is used to pass a ground to the motor through a relay between post 87a and post 30 in the relays "unswitched" state.

Note: You may have to switch the connections at micro switches at the "NC" post to get the switching correct.